



# Plug Valves

# Pressure Balanced Plug Valve

## Applicable Standards:

DESIGN & MANUFACTURE CONFORM WITH: API 6D/ISO 14313, ASME B16.34  
 CONNECTION DIMENSION CONFORMS WITH: ASME B16.5, DIN EN 1092  
 FIRE RESISTANCE DESIGN CONFORMS WITH: API 607/ISO 10497  
 INSPECTION & TEST CONFORMS WITH: API 6D, ISO 5208, API 598  
 MATERIAL CONFORMS WITH: ISO 15156

No	Part Name	No	Part Name
1	Body	9	Bolt
2	Cock body	10	Connection board
3	Stem	11	Stud
4	Driving dog	12	Nut
5	O-ring	13	Lower cover
6	Packing	14	Gasket

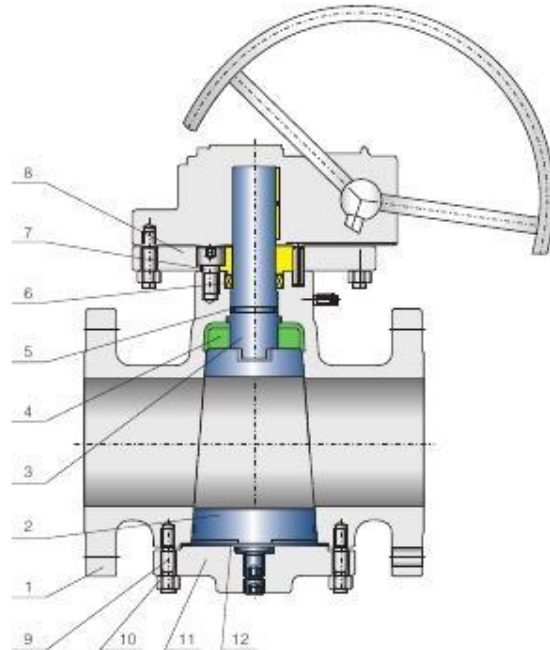

## Materials of parts

<b>Body</b>	WCB/LCB/CF8M/CF8/CF3M/CF3/WC6/WC9/CD3MN
<b>Cock body</b>	WCB+N/CA15/4140+ENP/CF8M/CF8/CF3M/CF3/CD3MN
<b>Stem</b>	F6a/4140+ENP/F304/F316/F304L/F316L/F51
<b>Lower cover</b>	A105/LF2/F304/F316/F304L/F316L/F51
<b>O-ring</b>	VITON/NBR
<b>Stud</b>	B7M/B8M/L7M/B16M
<b>Nut</b>	2HM/8M/7M/4M
<b>Gasket</b>	Flexible graphite+304/PTFE/304

Materials could be choosed according to customers' requirement & working condition.

## Plug Valve Introduction

### 一、 Usage.

It is mainly used for storage and transportation of oil and gas in the chemical industry, metallurgy, paper making, food processing, shipbuilding and other industries, used to open or close, and with pneumatic and electrical devices can also achieve the long-distance operation, to ensure personal safety.

### 二、 Features.

- 1、 lockup device, manual operation, in order to prevent misoperation, valve can be equipped with padlock device.
- 2、 Anti-static structure, when a fire break out, the metal seal forms to prevent large leakage of media
- 3、 valve body and stem can finish emergency injection seal, through the grease injection valve, the stop-leak compound can achieve a short-time seal, therefor to buy time handling the scene.

# Pressure Balanced Plug Valve 150Lb/300Lb

## Applicable Standards:

DESIGN & MANUFACTURE CONFORM WITH: API 6D/ISO 14313, ASME B16.34  
 CONNECTION DIMENSION CONFORMS WITH: ASME B16.5, DIN EN 1092  
 FIRE RESISTANCE DESIGN CONFORMS WITH: API 607/ISO 10497  
 INSPECTION & TEST CONFORMS WITH: API 6D, ISO 5208, API 598  
 MATERIAL CONFORMS WITH: ISO 15156

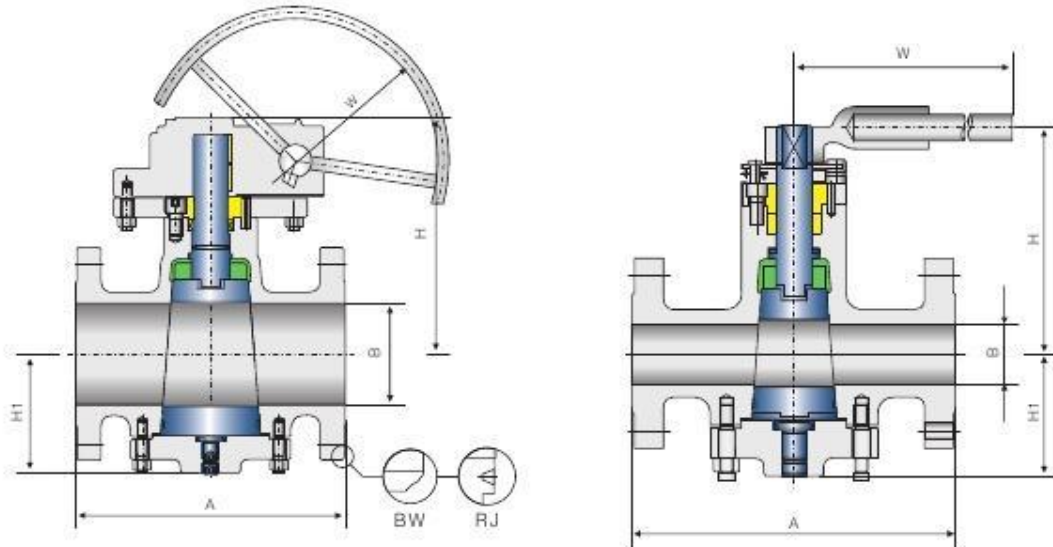

## Dimensional datas

NPS inch	DN	A mm	B mm	H mm	H1 mm	W mm	M(RF) kg	T N.m	NPS inch	DN	A mm	B mm	H mm	H1 mm	W mm	M(RF) kg	T N.m
<b>Short Series Type ANSI Class 150Lb</b>									<b>Venturi Type ANSI Class 150Lb</b>								
2	50	178	51	175	106	350	18	98	★ 10	250	533	252	420	255	600	375	2166
3	80	203	76	190	127	600	31	180	★ 12	300	610	303	492	316	600	420	3199
4	100	229	102	214	158	700	50	302	★ 14	350	686	334	498	320	600	480	4849
★ 6	150	267	152	270	185	900	93	628	★ 16	400	762	385	645	368	700	590	6032
★ 8	200	292	201	370	220	600	250	2032	★ 18	450	864	436	687	426	760	713	9142
★ 10	250	330	252	420	250	600	330	2166	★ 20	500	914	487	742	477	760	880	12022
★ 12	300	356	303	490	310	600	360	3199	★ 24	600	1067	589	798	522	760	1203	19424

## Dimensional datas

NPS inch	DN	A mm	B mm	H mm	H1 mm	W mm	M(RF) kg	T N.m	NPS inch	DN	A mm	B mm	H mm	H1 mm	W mm	M(RF) kg	T N.m
<b>Short Series Type ANSI Class 300Lb</b>									<b>Venturi Type ANSI Class 300Lb</b>								
2	50	216	51	184	108	500	25	172	6	150	403	152	307	200	900	144	1080
2 1/2	70	241	62	190	115	550	33	198	★ 8	200	419	303	390	230	600	280	3208
3	80	283	76	195	137	600	40	218	★ 10	250	457	252	433	255	600	370	3258
4	100	305	102	265	168	700	70	536	★ 12	300	502	303	500	320	700	408	5202
★ 6	150	403	152	307	200	900	144	1080	★ 14	350	762	334	630	340	700	510	8486
★ 8	200	419	201	390	230	600	280	3208	★ 16	400	838	385	740	376	762	630	10696
★ 10	250	457	252	433	255	600	370	3258	★ 18	450	914	436	788	436	762	750	15940
★ 12	300	502	303	500	320	700	408	5202	★ 20	500	991	487	833	497	762	890	21040
									★ 24	600	1143	589	889	543	762	1035	24082

Note: ★ Turbine drives

# Pressure Balanced Plug Valve 600Lb/900Lb/1500Lb

## Applicable Standards:

DESIGN & MANUFACTURE CONFORM WITH; API 6D/ISO 14313, ASME B16.34  
 CONNECTION DIMENSION CONFORMS WITH; ASME B16.5, DIN EN 1092  
 FIRE RESISTANCE DESIGN CONFORMS WITH; API 607/ISO 10497  
 INSPECTION & TEST CONFORMS WITH; API 6D, ISO 5208, API 598  
 MATERIAL CONFORMS WITH; ISO 15156

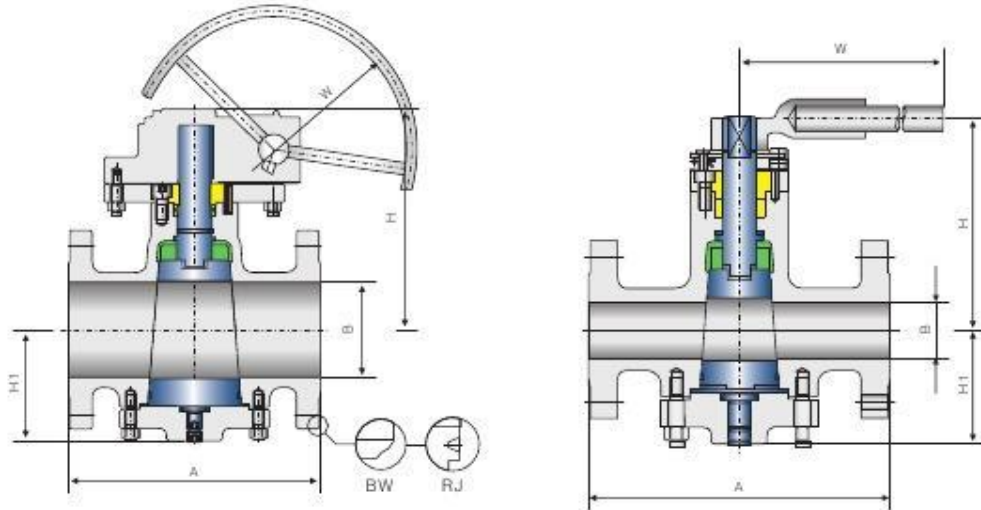

## Dimensional datas

NPS inch	DN	A mm	B mm	H mm	H1 mm	W mm	M(RF) kg	T N.m	NPS inch	DN	A mm	B mm	H mm	H1 mm	W mm	M(RF) kg	T N.m
<b>Reduced Bore Type ANSI Class 600Lb</b>									<b>Venturi Type ANSI Class 600Lb</b>								
2	50	292	51	194	108	500	30	292	6	150	403	152	307	200	900	144	1080
2 1/2	65	330	62	200	115	550	40	322	★ 8	200	419	303	390	230	600	280	3208
3	80	356	76	205	137	780	48	380	★ 10	250	457	252	433	255	600	370	3258
4	100	432	102	270	168	1100	85	918	★ 12	300	502	303	500	320	700	408	5202
★ 6	150	559	152	340	200	600	194	1814	★ 14	350	762	334	630	340	700	510	8486
★ 8	200	660	201	405	230	600	305	5114	★ 16	400	838	385	740	376	762	630	10696
★ 10	250	787	252	460	255	700	625	6088	★ 18	450	914	436	788	436	762	750	15940
									★ 20	500	991	487	833	497	762	890	21040
									★ 24	600	1143	589	889	543	762	1035	24082

## Dimensional datas

NPS inch	DN	A mm	B mm	H mm	H1 mm	W mm	M(RF) kg	T N.m	NPS inch	DN	A mm	B mm	H mm	H1 mm	W mm	M(RF) kg	T N.m
<b>Reduced Bore Type ANSI Class 900Lb</b>									<b>Venturi Type ANSI Class 900Lb</b>								
2	50	368	51	215	120	700	50	417	★ 6	150	610	152	365	210	600	240	2548
3	80	381	76	250	145	800	70	540	★ 8	200	737	201	405	240	600	410	7022
4	100	457	102	300	180	1100	116	1258	★ 10	250	838	252	460	265	762	860	8516
★ 6	150	610	152	365	210	600	240	2548	★ 12	300	965	303	510	335	762	1150	11986
★ 8	200	737	201	405	240	700	410	7022	★ 16	400	1130	373	600	390	762	1960	20326
★ 10	250	838	252	460	265	762	860	8516									

## Dimensional datas

NPS inch	DN	A mm	B mm	H mm	H1 mm	W mm	M(RF) kg	T N.m	NPS inch	DN	A mm	B mm	H mm	H1 mm	W mm	M(RF) kg	T N.m
<b>Reduced Bore Type ANSI Class 1500Lb</b>									<b>Venturi Type ANSI Class 1500Lb</b>								
2	50	368	51	215	120	700	50	654	★ 6	150	705	144	390	220	600	325	4022
3	80	470	76	60	150	1000	88	862	★ 8	200	832	192	415	260	762	520	10848
4	100	546	102	320	185	600	160	2064	★ 10	250	911	239	480	280	762	970	13388
★ 6	150	705	144	390	220	600	325	4022	★ 12	300	1130	287	540	360	762	1450	18792
★ 8	200	832	192	415	260	762	520	10848									

Note: ★ Turbine drives

# Sleeve Soft Sealed Plug Valve 150Lb/300Lb

## Applicable Standards:

- STEEL PLUG VALVES API 599/API 6D
- STEEL PLUG VALVES ISO 14313
- FIRE SAFE, API 607
- ANTI STATICS, API 599
- STEEL VALVES, ASME B16.34
- FACE TO FACE ASME B16.10
- END FLANGES, ASME B16.5
- BUTTWELDING ENDS ASME B16.25
- INSPECTION AND TEST, API 598/ API 6D

## Design descriptions:

- RUGGED, HEAVY-DUTY BODY
- BOLTED BONNET CAP
- PTFE SLEEVED, TAPERED PLUG
- LARGE PORT OPENINGS
- NON-LUBRICATED
- STEM INTEGRAL WITH PLUG
- IN-LINE ADJUSTMENT
- FIRE SAFE CONSTRUCTION
- ANTI STATICS DEVICE
- STOPPER DEVICE
- RENEWABLE SEAT RING
- FLANGED OR BUTTWELDING ENDS
- AVAILABLE WITH WG OPERATOR

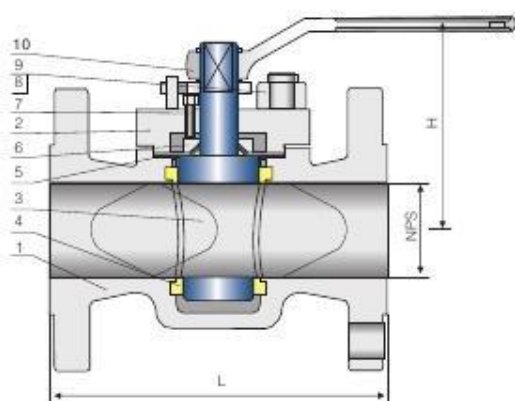

## Materials of parts

No	Part Name	Carbon Steel	ASTM Materials 18Cr-9Ni-2Mo	Carbon Steel
1	Body	A216-WCB	A351-CF8M	A352-LCB
2	Bonnet	A216-WCB	A351-CF8M	A352-LCB
3	Plug	A182-F3041)	A182-F316	A182-F304 <sup>1)</sup>
4	Sleeve	Glass Filled PTFE		
5	Bonnet Gasket	Graphite+304 <sup>2)</sup>	Graphite+316 <sup>2)</sup>	Graphite+304 <sup>2)</sup>
6	Adjusting Gasket	A182-F6a	A182-F316	A182-F6a
7	Adjusting Bolt	A193-B7	A193-B8	A320-L7
8	Bonnet Stud	A193-B7	A193-B8	A320-L7
9	Bonnet Bolt	A194-2H	A194-8	A194-4
10	Handle	Carbon Steel		
11	Diaphragm	A167-304+PTFE	A167-316+PTFE	A167-304+PTFE
12	Packing	Graphite		
13	Gland Flange	A216-WCB	A217-WC6	A352-LCB

Note: 1)A105+ENP optional  
2)lacked construction

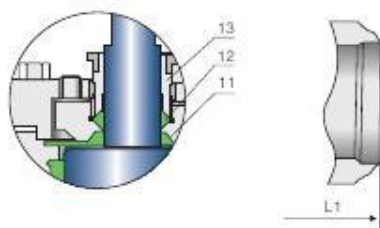

## Dimensional datas

NPS	DN	ANSI Class150Lb					ANSI Class300Lb														
		L (RF)	L1 (BW)	H	W	WT(kg)	L (RF)	L1 (BW)	H	W	WT(kg)										
2	50	7.00	178	10.50	267	6.00	150	13	320	17	13	8.5	216	10.50	267	6.00	150	13	320	17	13
2 1/2	65	7.50	191	12.00	305	6.50	165	14	350	20	14	9.5	241	12.00	305	6.50	165	14	350	20	14
3	80	8.00	203	13.00	330	7.12	180	16	410	25	17.5	11.0	283	13.00	330	7.12	180	16	410	25	17.5
4	100	9.00	229	14.00	356	15.00	380	13	320	40	29	12.0	305	14.00	356	15.00	380	13	320	40	29
6	150	10.50	267	18.00	457	20.50	520	13	320	70	55	16.0	403	18.00	457	20.50	520	13	320	70	55
8	200	11.50	292	20.50	521	22.88	580	13	320	135	110	16.5	419	20.50	521	22.88	580	13	320	135	110
10	250	13.00	330	22.00	559	24.50	620	14	350	220	182	18.0	457	22.00	559	24.50	620	14	350	220	182
12	300	14.00	356	25.00	635	26.75	680	15	380	300	247	20.0	502	25.00	635	26.75	680	15	380	300	247
in	mm	in	mm	in	mm	in	mm	in	mm	RF	BW	in	mm	in	mm	in	mm	in	mm	RF	BW

# Sleeve Soft Sealed Plug Valve 600Lb/900Lb

## Applicable Standards:

- STEEL PLUG VALVES API 599/API 6D
- STEEL PLUG VALVES ISO 14313
- FIRE SAFE, API 607
- ANTI STATICS, API 599
- STEEL VALVES, ASME B16.34
- FACE TO FACE ASME B16.10
- END FLANGES, ASME B16.5
- BUTTWELDING ENDS ASME B16.25
- INSPECTION AND TEST, API 598/ API 6D

## Design descriptions:

- RUGGED, HEAVY-DUTY BODY
- BOLTED BONNET CAP
- PTFE SLEEVED, TAPERED PLUG
- LARGE PORT OPENINGS
- NON-LUBRICATED
- STEM INTEGRAL WITH PLUG
- IN-LINE ADJUSTMENT
- FIRE SAFE CONSTRUCTION
- ANTI STATICS DEVICE
- STOPPER DEVICE
- RENEWABLE SEAT RING
- FLANGED OR BUTTWELDING ENDS
- AVAILABLE WITH WG OPERATOR

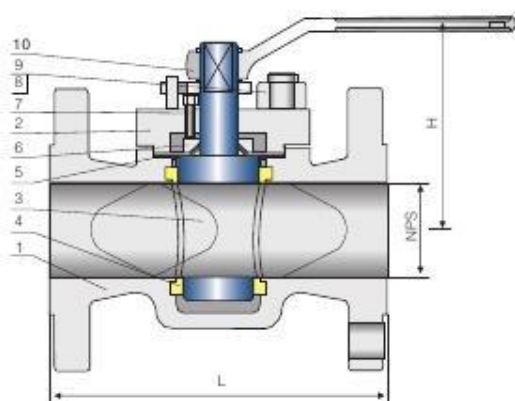

## Materials of parts

No	Part Name	Carbon Steel	ASTM Materials 18Cr-9Ni-2Mo	Carbon Steel
1	Body	A216-WCB	A351-CF8M	A352-LCB
2	Bonnet Cap	A216-WCB	A351-CF8M	A352-LCB
3	Plug	A182-F304 <sup>1)</sup>	A182-F316	A182-F304 <sup>1)</sup>
4	Sleeve	Glass Filled PTFE		
5	Bonnet Gasket	Graphite+304 <sup>2)</sup>	Graphite+316 <sup>2)</sup>	Graphite+304 <sup>2)</sup>
6	Adjusting Gasket	A182-F6a	A182-F316	A182-F6a
7	Adjusting Bolt	A193-B7	A193-B8	A320-L7
8	Bonnet Stud	A193-B7	A193-B8	A320-L7
9	Bonnet Bolt	A194-2H	A194-B	A194-4
10	Handle	Carbon Steel		
11	Diaphragm	A216-WCB	A217-WC6	A352-LCB
12	Packing	Graphite		
13	Gland Flange	A216-WCB	A217-WC6	A352-LCB

Note: 1)A105+ENP optional  
2)lacked construction

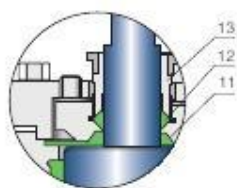

## Dimensional datas

NPS	DN	L (RF)		L1 (BW)		H		W		WT(kg)		L (RF)		L1 (BW)		H		W		WT(kg)	
ANSI Class600Lb											ANSI Class900Lb										
2	50	11.50	292	11.62	295	6.12	155	14	350	28	21	14.50	368	14.62	371	6.12	155	14	350	52	32
2 <sup>1</sup> / <sub>2</sub>	65	13.00	330	13.12	333	6.75	170	16	410	33	23.5	16.50	419	16.62	422	6.75	170	16	410	60	34
3	80	14.00	356	14.12	359	7.25	185	13	320	387	23	15.00	381	15.12	384	7.25	185	13	320	70	47
4	100	16.00	432	16.12	435	15.38	390	13	320	75	46	18.00	457	18.12	460	15.38	390	13	320	92	55
6	150	19.50	559	19.62	562	20.88	530	13	320	142	97	24.00	610	24.12	613	20.88	530	13	320	195	120
8	200	23.50	660	23.62	664	23.25	590	14	350	250	167	29.00	737	29.12	740	23.25	590	14	350	320	197
10	250	26.50	787	26.62	791	24.88	630	15	350	365	227	33.00	838	33.12	841	24.88	630	15	380	455	277
12	300	30.00	838	30.12	841	27.12	690	15	380	515	354	38.00	965	38.12	968	27.12	690	15	380	625	405
in	mm	in	mm	in	mm	in	mm	in	mm	RF/RTJ	BW	in	mm	in	mm	in	mm	in	mm	RF/RTJ	BW